

ODIS

IRRIGATION EQUIPMENT LTD.

HYDROCYCLONE SAND SEPARATORS SERIES 5000

Registered Patent

APPLICATIONS

- Used for separation of sand and other solid matter from water or other liquids.
- Protects pump, valves and irrigation systems from damage and abrasion caused by suspended solids.
- Pre-filtering of liquids prior to gravel filter, screen filters etc.
- For agriculture, domestic, industrial and municipal use.



ODIS Filtration *is The Heart* of Every Irrigation System

DESCRIPTION

The ODIS hydrocyclone separator is a simple device, easy to operate and maintain. It has no moving parts or screens. The hydrocyclone separates sand and other solid matter with very little head loss and 90% or better efficiency, no head loss build up and no clogging by solids being separated.

Its versatility in system configurations and its economy in installation are some of its great advantages.

The hydrocyclones use a tangential injection flow process, enhancing the centrifugal forces and moving solid particles outwards. The dispersed particles, move downwards in a spiral path into an underflow chamber, while clean liquid moves upwards to the center of the spiral, towards the top outlet.

Specially designed Rubber Insert (Registered Patent) protects the cone against erosion and increases separation efficiency.

The underflow chamber is drained automatically without interfering with the proper functioning of the hydrocyclone.

Available in the following inlet sizes: ¾", 1", 1 ½", 2", 3", 4", 6", 8".

Available with three end connections: Thread (M), Flange (F), Victaulic (V).

The hydrocyclone has a 120 micron protective coating of extra durable polyester applied electrostatically and oven cured on a zinc-phosphate layer for maximal anti-corrosion protection.

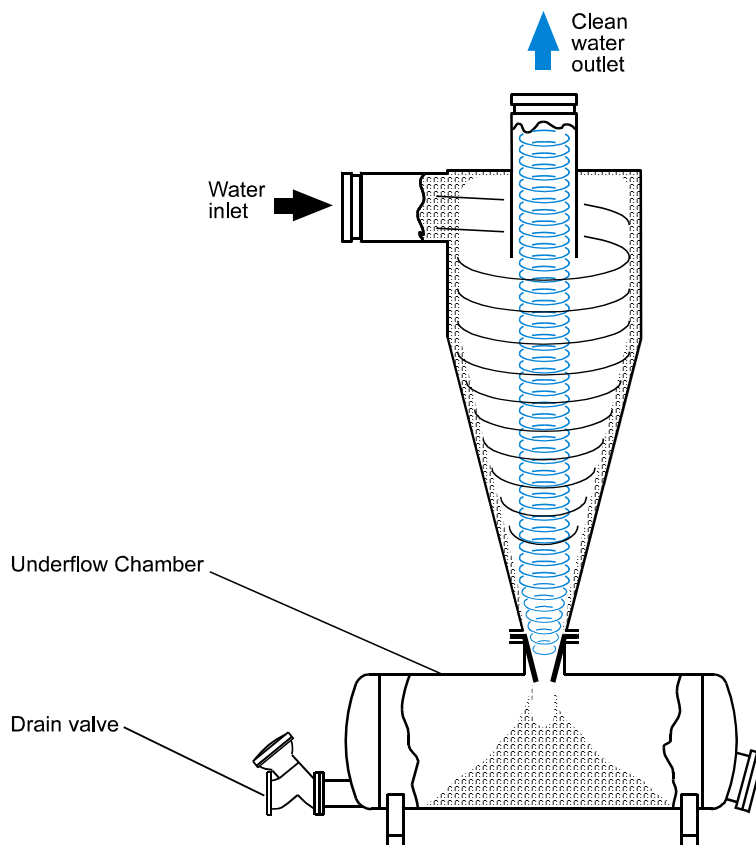

FLOW SCHEME OF HYDROCYCLONE AND MODE OF SEPARATION

Dimensions & Weight

Metric Units

Model	B		D	H	H1	H2	H3	L	T	Weight
	mm	inch	inch	mm	mm	mm	mm*	mm	mm	kg***
50307	20	3/4"	3"	400**	320	285	-	120	32	8
50410	25	1"	4"	460**	380	345	-	140	40	9
50615	40	1 1/2"	6"	630**	490**	425	-	240	61	19
50820	50	2"	8"	735**	575**	530	-	295	80	20
50830	80	3"	8"	830**	660**	625	-	300	65	27
51243	100 in/80 out	4" in/3" out	12"	1330	1130	725	-	500	105	66
51640	100	4"	16"	1720	1480	970	100 ÷ 150*	600	145	125
52060	150	6"	20"	1900	1610	1150	100 ÷ 150*	600	170	172
52460	150	6"	24"	2155	1860	1405	100 ÷ 150*	600	220	205
53080	200	8"	30"	2825	2360	1925	100 ÷ 150*	700	265	365

U.S. Units

Model	B	D	H	H1	H2	H3	L	T	Weight
	inch	inch	inch	inch	inch	inch*	inch	inch	lbs ***
50307	3/4"	3"	16**	12.6	11.2	-	4.7	1.2	18
50410	1"	4"	18**	15	13.6	-	5.5	1.6	20
50615	1 1/2"	6"	25**	19.3**	16.7	-	9.5	2.4	42
50820	2"	8"	29**	22.6**	20.9	-	11.6	3.2	44
50830	3"	8"	33**	26**	24.6	-	11.8	2.6	60
51243	4" in/3" out	12"	52	44.5	28.5	-	19.7	4.1	146
51640	4"	16"	68	58.3	38.2	3.9 ÷ 5.9*	23.6	5.7	276
52060	6"	20"	75	63.4	45.3	3.9 ÷ 5.9*	23.6	6.7	379
52460	6"	24"	85	73.2	55.3	3.9 ÷ 5.9*	23.6	8.7	452
53080	8"	30"	111	93	75.8	3.9 ÷ 5.9*	27.6	10.4	805

* H3 - Applicable on models with the 120, 220 and 320 liters underflow chamber

** Height for underflow chambers without legs

*** Weight including underflow chamber

• Models with 2 and 10 liters underflow chambers with legs, add 80 ± 15 mm (3.15 ± 0.2 inch) to dimensions H and H1

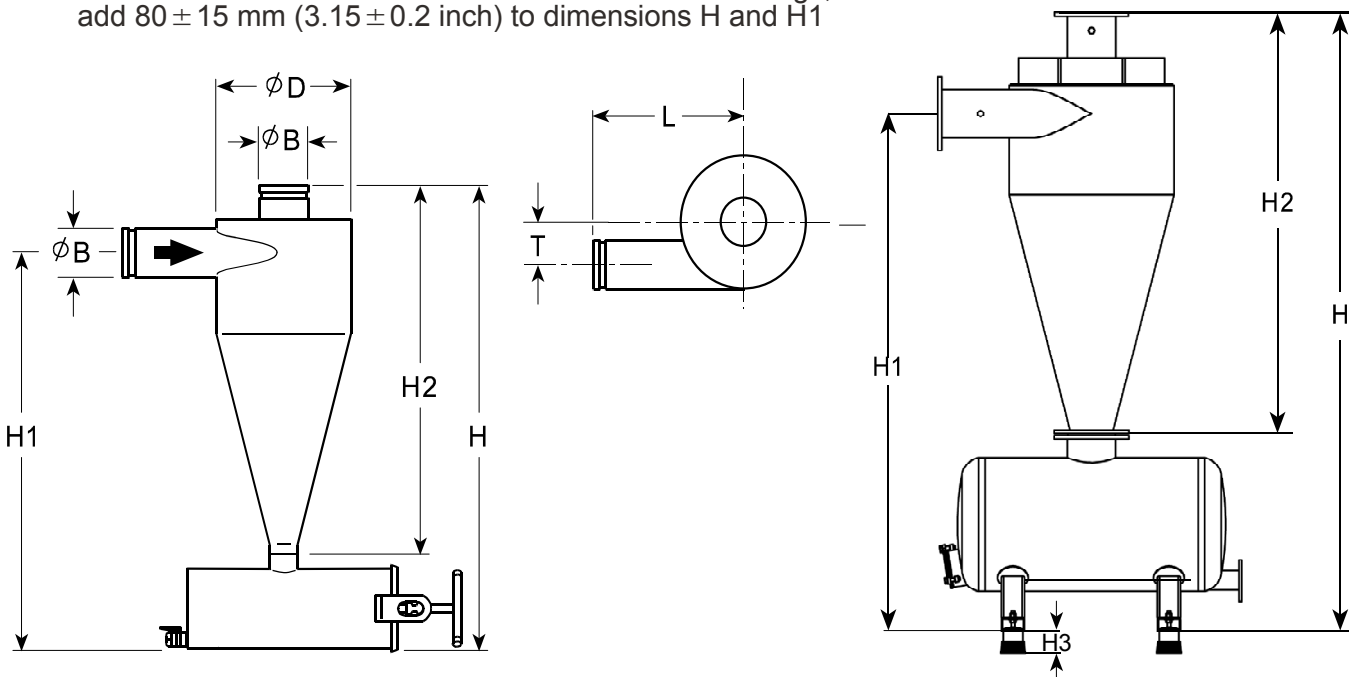

Recommended Flow Rates
Metric Units

Model	Inlet / Outlet Diameters		Recommended Flow Rate	Standard Underflow Chamber
	inch	mm	m ³ /h	liters
50307	¾"	20	2 to 3.5	2
50410	1"	25	3.5 to 7.5	2
50615	1½"	40	7.5 to 12	10
50820	2"	50	11 to 17	10
50830	3"	80	18 to 34	10
51243	4" in/3" out	100 in/80 out	35 to 52	60
51640	4"	100	52 to 82	120
52060	6"	150	98 to 160	220
52460	6"	150	140 to 230	220
53080	8"	200	230 to 360	320

U.S. Units

Model	Inlet / Outlet Diameters		Recommended Flow Rate	Standard Underflow Chamber
	inch		U.S. gpm	U.S. gallons
50307	¾"		8.8 to 15	0.5
50410	1"		15 to 33	0.5
50615	1½"		33 to 53	2.6
50820	2"		48 to 75	2.6
50830	3"		79 to 150	2.6
51243	4" in/3" out		154 to 229	16
51640	4"		229 to 361	32
52060	6"		431 to 704	58
52460	6"		616 to 1012	58
53080	8"		1012 to 1584	85

NOTE:

The size of the Hydrocyclone Separator must suit the actual flow rate in the pipe. A larger or a smaller separator would not maintain the required speed of circulation, and the quality of filtration would be affected.

Technical Data

- Recommended head loss for effective operation 0.2 - 0.5 bar (3 - 8 psi).
- Maximum working pressure: 8 bar (120 psi).
- Horizontal water inlet/top vertical outlet.
- Separation efficiency: as a rule the separation improves as the hydrocyclone diameter decreases and head loss increases.
- Miniature hydrocyclones may be used for easy sampling of liquids, for determining filter (including larger hydrocyclones) operation and efficiency, and for testing the feasibility of hydrocyclone operation for the problem at hand.

Inserts

- To improve efficiency, each hydrocyclone is equipped with inserts at the bottom end of the cone.
- Models 50615, 50820, 50830, 51243, 51640, 52060, 52460, 53080 rubber insert.

Do not use water containing Copper Sulfate!!!

Copper Sulfate is highly Corrosive to iron, it will damage filter body, pipes and welds, performing cracks , pinholes Etc...

Protective Coating

120 micron extra-durable polyester or epoxy layer for anti corrosion protection.

Pressure Relief Valve

A pressure relief valve must be inserted before the filtering installation if pressure is not controlled effectively.

End Connections

Thread (M)
Flange (F)
Victaulic (V)

Underflow Chamber Connections

- Thread: models 50307, 50410.
- Flange: models 51243, 51640, 52060, 52460, 53080.
- Victaulic: models : 50615, 50820, 50830
- Each filter is designed and manufactured in order to achieve the highest standard of quality and finish.

HEAD LOSS/ FLOW RATE

Metric Units

Head Loss

Model	Head Loss dP (bar)					
	0.2	0.3	0.4	0.5	0.6	0.7
	Flow Rate Q (m ³ /h)					
50307 (3/4")	2.1	2.6	3.0	3.3	3.6	3.9
50410 (1")	3.4	4.2	4.9	5.4	6.0	6.4
50615 (1 1/2")	7.6	9.3	10.8	12.0	13.2	14.2
50820 (2")	10.1	12.4	14.3	16.0	17.5	18.9
50830 (3")	21.1	25.9	29.9	33.4	36.6	39.5
51243 (4"x3")	30.4	37.2	43.0	48.1	52.7	56.9
51640 (4")	50.1	61.3	70.8	79.2	86.8	93.7
52060 (6")	96.2	117.8	136.0	152.0	166.5	179.9
52460 (6")	138.6	169.8	196.1	219.2	240.1	259.4
53080 (8")	216.8	265.6	306.7	342.9	375.7	405.8
Recommended Range						

Head Loss/Flow Rate

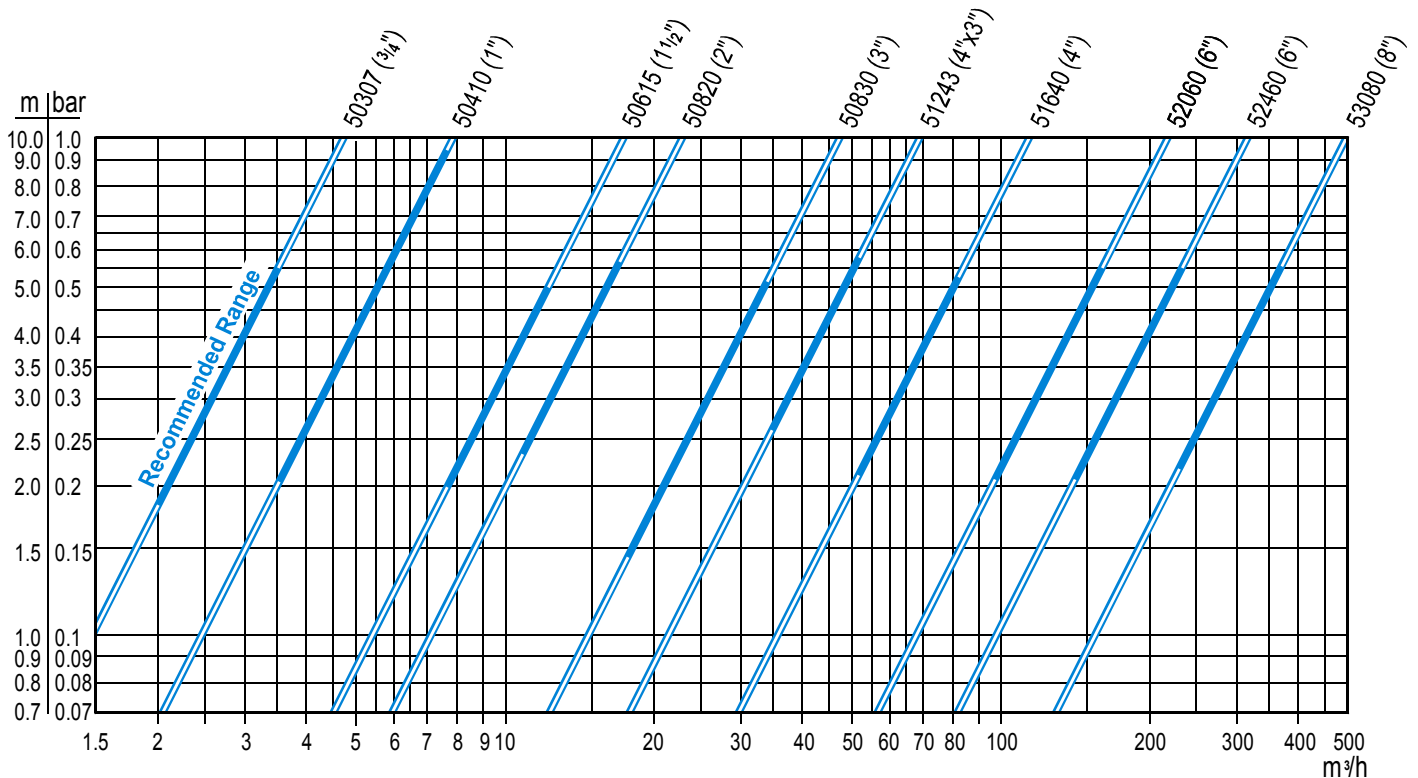

■ 1 bar=100 kPa=1.02 kg/cm²=10.2 m (W.C)=14.5 psi

HEAD LOSS/ FLOW RATE

U.S. Units

Head Loss

Model	Head Loss dP (psi)					
	3	4.5	6	7.5	9	10.5
	Flow Rate Q (U.S. gpm)					
50307 (3/4")	9.4	11.5	13.3	14.9	16.3	17.6
50410 (1")	15.4	18.9	21.8	24.4	26.7	28.9
50615 (1 1/2")	34.0	41.7	48.2	53.8	59.0	63.7
50820 (2")	45.3	55.4	64.0	71.6	78.4	84.7
50830 (3")	94.5	115.8	133.7	149.5	163.7	176.9
51243 (4"x3")	136.2	166.8	192.6	215.3	235.9	254.8
51640 (4")	224.3	274.7	317.2	354.7	388.5	419.7
52060 (6")	430.6	527.4	609.0	680.9	745.9	805.6
52460 (6")	620.9	760.4	878.1	981.7	1075.4	1161.6
53080 (8")	971.3	1189.6	1343.7	1535.8	1682.4	1817.0
Recommended Range						

Head Loss/Flow Rate

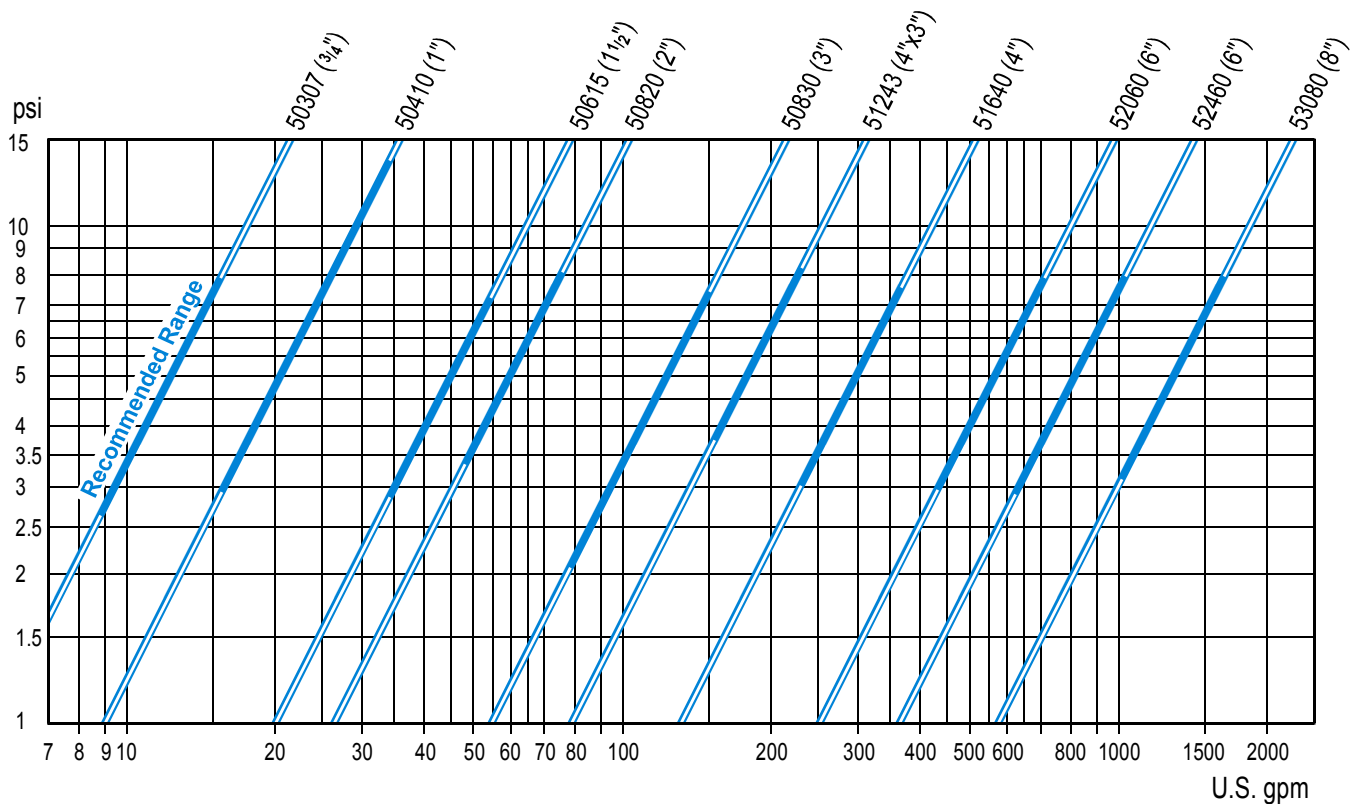

■ 1 psi=0.069 bar=6.9 kPa=0.07 kg/cm²=0.7 m (W.C)

ILLUSTRATED PARTS BREAKDOWN

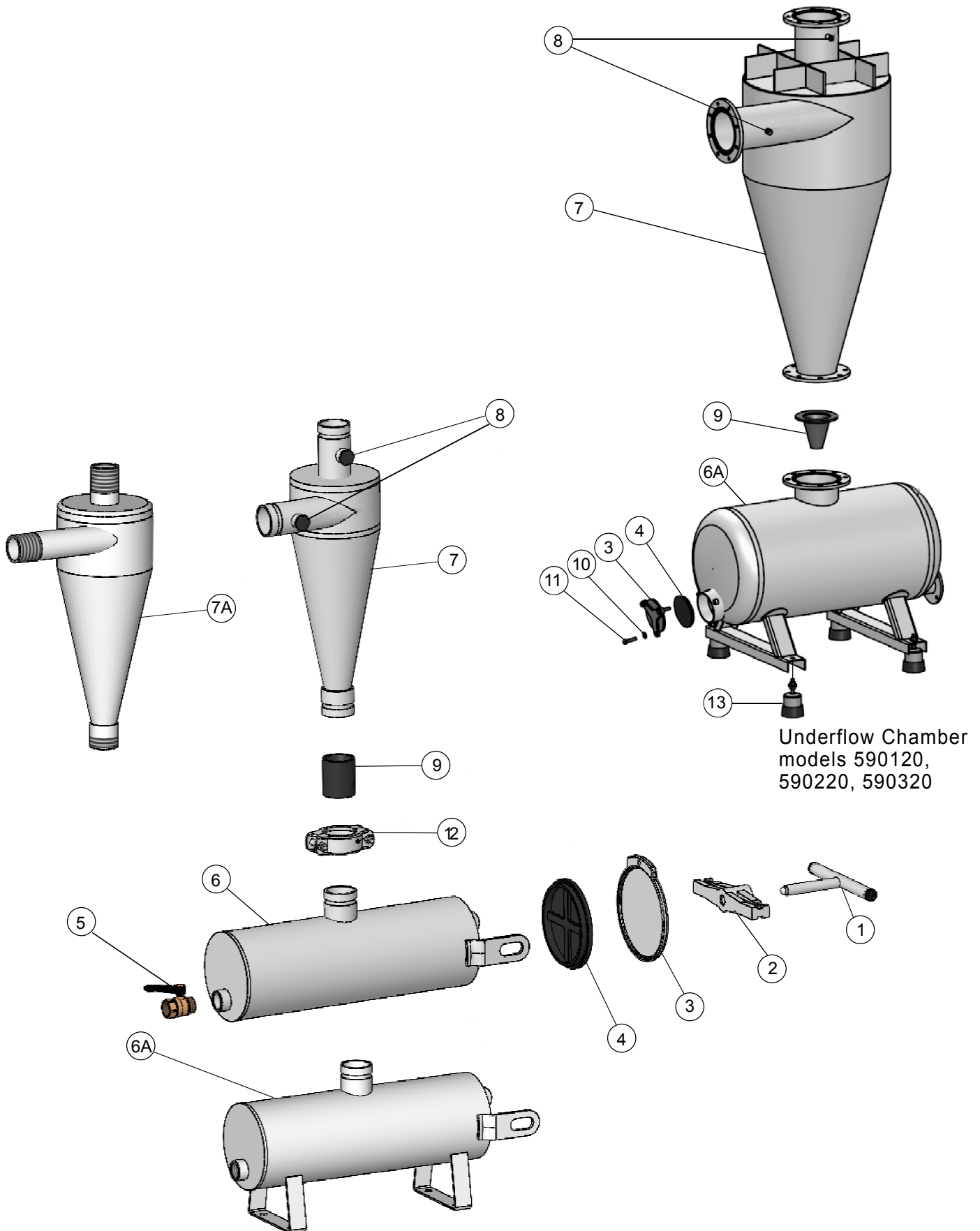

Underflow Chamber
models 590120,
590220, 590320

Catalog Numbers - Underflow Chambers

Model		590002	590010	590060	590120	590220	590320
Capacity (Liters)		2	10	60	120	220	320
Capacity (U.S. Gallons)		0.5	2.6	16	32	58	85
Part No.	Description						
1	Handle	E000101	E000100	-	-	-	-
2	Tightening Bracket	E000214	E000216	-	-	-	-
3	Cover	E000240	E000260	E004260	E400260	E400260	E400260
4	Cover Gasket	E001340	E001361	E004365	E004365	E004365	E004365
5	Drain Valve	PM1050110 (1/2")	PM1100010 (1")	PM1200010 (2")	-	-	-
6	Body - No legs	A590002	A590010-V3	-	-	-	-
6A	Body - With legs	A591002	A591010-V3	A590060-F6	A590120-F6	A590220-F8	A590320-F8
9	Rubber Insert	-	E545950	E550952	E550952	E560952	E560952
10	Washer	-	-	L200004	L200004	L200004	L200004
11	Bolt	-	-	L1616508060U	L1616508060U	L1616508060U	L1616508060U
12	Victaulic connector	-	905110003	905110003	-	-	-
13	Adjustable Leg	-	-	-	Y188606	Y188606	Y188606

- **When ordering, please specify underflow chamber capacity.**
- Aimed at continued improvement, ODIS reserves the right to change specifications without prior notice.

Catalog Numbers - Hydrocyclones

Part No.	Description	Model				
		50307 (3/4")	50410 (1")	50615 (1 1/2")	50820 (2")	50830 (3")
7	Body	-	-	A50615-V3	A50820-V3	A50830-V3
7A	Body	A50307	A 50410	-	-	-
8	Male Plug	-	-	H070305 (1/2")	H070305 (1/2")	H070305 (1/2")
9	Rubber Insert	-	-	E545950	E545950	E545950

Part No.	Description	Model				
		51243(4"x3")	51640 (4")	52060 (6")	52460 (6")	53080 (8")
7	Body	A51243-F6	A51640-F6	A52060-F8	A52460-F8	A53080-F8
8	Male Plug	H070305 (1/2")	H070305 (1/2")	H070305 (1/2")	H070305 (1/2")	H070305 (1/2")
9	Rubber Insert	E550952	E550952	E560952	E560952	E560952

GENERAL INSTRUCTIONS

Operation

- Normal working conditions are achieved when head loss on the hydrocyclone is not less than 0.2 bar (3 psi).
- Recommended head loss 0.2 - 0.5 bar (3 - 7.5 psi).
- A head loss of more than 0.5 bar (7.5 psi) might induce increased erosion.
- A head loss of less than 0.2 bar (3 psi) will reduce the separation efficiency.
- Maximal operational pressure should not exceed 8 bar (120 psi).
- As a rule, the separation improves as the hydrocyclone diameter decreases and the pressure loss increases.

Do not use water containing Copper Sulfate!!!

Copper Sulfate is highly Corrosive to iron, it will damage filter body, pipes and welds, performing cracks, pinholes Etc...

Underflow Chamber Flushing

- The underflow chamber is flushed automatically with an irrigation controller or computer at periodic intervals.
- When a manual valve is installed, drain the underflow chamber at periodic intervals according to the recommendations.
- The underflow chamber should be drained when it is $\frac{1}{3}$ full.
- Do not let the underflow chamber get filled more than $\frac{1}{2}$ of its volume.

Installation

- Install and connect the hydrocyclone vertically with the underflow chamber (underneath the hydrocyclone).
- Special attention must be given to the correct flow direction: horizontal inlet and top vertical outlet are clearly marked by arrows.
- A double chamber hydraulic valve must be installed on the outlet opening (5) of the underflow chamber.
- Connect the controller to the valve.
- Insert the batteries inside the controller and close the cover tightly.
- Check that the actual flow rate through the hydrocyclone is within the recommended rate. Inadequate flow rate will result in reduced performance.
- Adjust the controller as follows:
 - Flushing time for underflow chambers 5 - 60 liters: 15 - 20 seconds.
 - Flushing time for underflow chambers 120 - 320 liters: 30 - 40 seconds.
 - Time between flushings: 30 - 120 minutes.If the water contain high load of dirt, shorten the time between flushings.
- If more than one hydrocyclone is installed, leave sufficient space between units to facilitate maintenance.
- All hydrocyclones are supplied with instructions for correct assembly, installation, operation and maintenance.
- Specially designed manifolds (series 9000), are available for mounting multiple filter arrays
- A pressure relief valve must be inserted before the filtering installation if the pressure is not controlled effectively.

Periodic Cleaning of the Underflow Chamber

- Close valve at the inlet of the hydrocyclone.
- Open drain valve located at the bottom of the underflow chamber to release pressure and drain.
- Take off the cover (3).
- Remove all the sediments collected in the underflow chamber.
- Rinse thoroughly the inside of the empty underflow chamber.
- Check that the insert is not damaged and replace if necessary.
- Replace the cover (3) on the underflow chamber, so that cover gasket (4) fits over it.
- Mount tightening bracket (2) and tightening handle (1) properly.

WARNING

- Do not tighten or open cover during operation or under pressure.

Maintenance

- Each hydrocyclone is supplied with maintenance instructions as well as assembly, installation and operation instructions.
- Apply a layer of grease to thread of handle (1) once a year.
- Any damage to the protective coating must be repaired without delay.
- Prior to the application of the protective paint, thoroughly clean the damaged spot with wire brush.

How To Order Odis Hydrocyclones

1. Type of hydrocyclone required.
2. Catalog Number of hydrocyclone.
3. End connections: Thread (M)
Flange (F)
Victaulic (V)
4. Min./ Max. pressure.
5. Maximal and Minimal flow rate.
6. Additional accessories: Nipples/Valves/Pilots/Relays/Manifolds/Pressure Gauges.
7. Hydrocyclone arrays: see chapter 1.
An array of hydrocyclones is preferable in case the flow rate is not constant.
8. Other than standard material, required for hydrocyclone body: stainless steel.
9. Special Coating Requirements: Inner Neoprene Rubber Lining.
10. Other than standard underflow chamber, please specify capacity.

PACKING / SHIPPING DATA
Metric Units

Model	Inlet / Outlet (inch)	Standard Underflow Chamber Capacity (liter)	Weight * * * (kg)	Filter per carton	Length (m)	Width (m)	Height (m)	Gross Volume (m ³)
50307 *	3/4"	2	8	1	0.48	0.24	0.24	0.028
50410 *	1"	2	9	1	0.48	0.24	0.24	0.028
50615 *	1 1/2"	5	18	1	0.65	0.35	0.23	0.052
50820 *	2"	10	20	1	0.66	0.54	0.22	0.078
50830 *	3"	10	27	1	0.66	0.54	0.22	0.078
51243	4"x3"	60	66	* *				0.6
51640	4"	120	125	* *				1.1
52060	6"	220	172	* *				1.35
52460	6"	220	205	* *				1.75
53080	8"	320	350	* *				2.72

*** Including Underflow Chamber.

** Not packed in a carton.

* Packed together with the Underflow Chamber.

UNDERFLOW PACKING / SHIPPING DATA
Metric Units

Model	Chamber Capacity (liter)	Weight (kg)	Units per carton	Length (m)	Width (m)	Height (m)	Gross Volume (m ³)
590002	2	6	1	0.42	0.16	0.17	0.011
590005	5	11	1	0.48	0.24	0.24	0.028
590010	10	17	1	0.75	0.25	0.25	0.047
590060	60	34	* *				0.14
590120	120	65	* *				0.26
590220	220	87	* *				0.45
590320	320	120	* *				0.61

** Not packed in a carton.

PACKING / SHIPPING DATA
U.S. Units

Model	Inlet / Outlet (inch)	Standard Underflow Chamber Capacity (U.S. gallon)	Weight * * * (lbs)	Filter per carton	Length (inch)	Width (inch)	Height (inch)	Gross Volume (cu. ft)
50307 *	3/4"	0.5	18	1	19	10	10	0.99
50410 *	1"	0.5	20	1	19	10	10	0.99
50615 *	1 1/2"	1.3	40	1	26	14	9	1.84
50820 *	2"	2.6	44	1	26	22	9	2.75
50830 *	3"	2.6	60	1	26	22	9	2.75
51243	4"x3"	16	146	* *				21.1
51640	4"	32	276	* *				38.8
52060	6"	58	379	* *				47.7
52460	6"	58	452	* *				61.8
53080	8"	85	770	* *				96.0

*** Including Underflow Chamber.

** Not packed in a carton.

* Packed together with the Underflow Chamber.

UNDERFLOW PACKING / SHIPPING DATA
U.S. Units

Model	Chamber Capacity (U.S. gallon)	Weight (lbs)	Units per carton	Length (inch)	Width (inch)	Height (inch)	Gross Volume (cu.ft)
590002	0.5	13	1	17	7	7	0.4
590005	1.3	24	1	19	10	10	1.0
590010	2.6	36	1	30	10	10	1.7
590060	16	75	* *				4.9
590120	32	144	* *				9.2
590220	58	192	* *				15.9
590320	85	265	* *				21.5

** Not packed in a carton.

