

SAP DESCRIPTION: **Station Sandstorm 2 x 36"**

SKU No. **71910-003805**

Maximum Flow Rate: 100m<sup>3</sup>/h  
 Recommended Flow Rate: 80m<sup>3</sup>/h

Inlet Pressure: **8 Bar**

Sheet Size: A4  
 Scale: 1:20

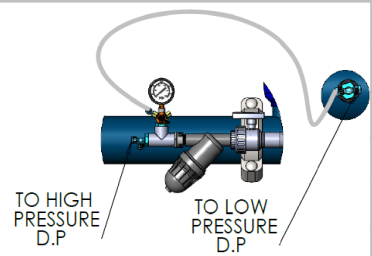

**PROPRIETARY AND CONFIDENTIAL**  
 THE INFORMATION CONTAINED IN THIS DRAWING IS THE SOLE PROPERTY OF NETAFIM. ANY REPRODUCTION IN PART OR AS A WHOLE WITHOUT THE WRITTEN PERMISSION OF NETAFIM IS PROHIBITED

Designed By		
Drawn By	KEREM	21/11/2019
Checked By		
QA		
Sheet: 1	Of: 3	Rev. -

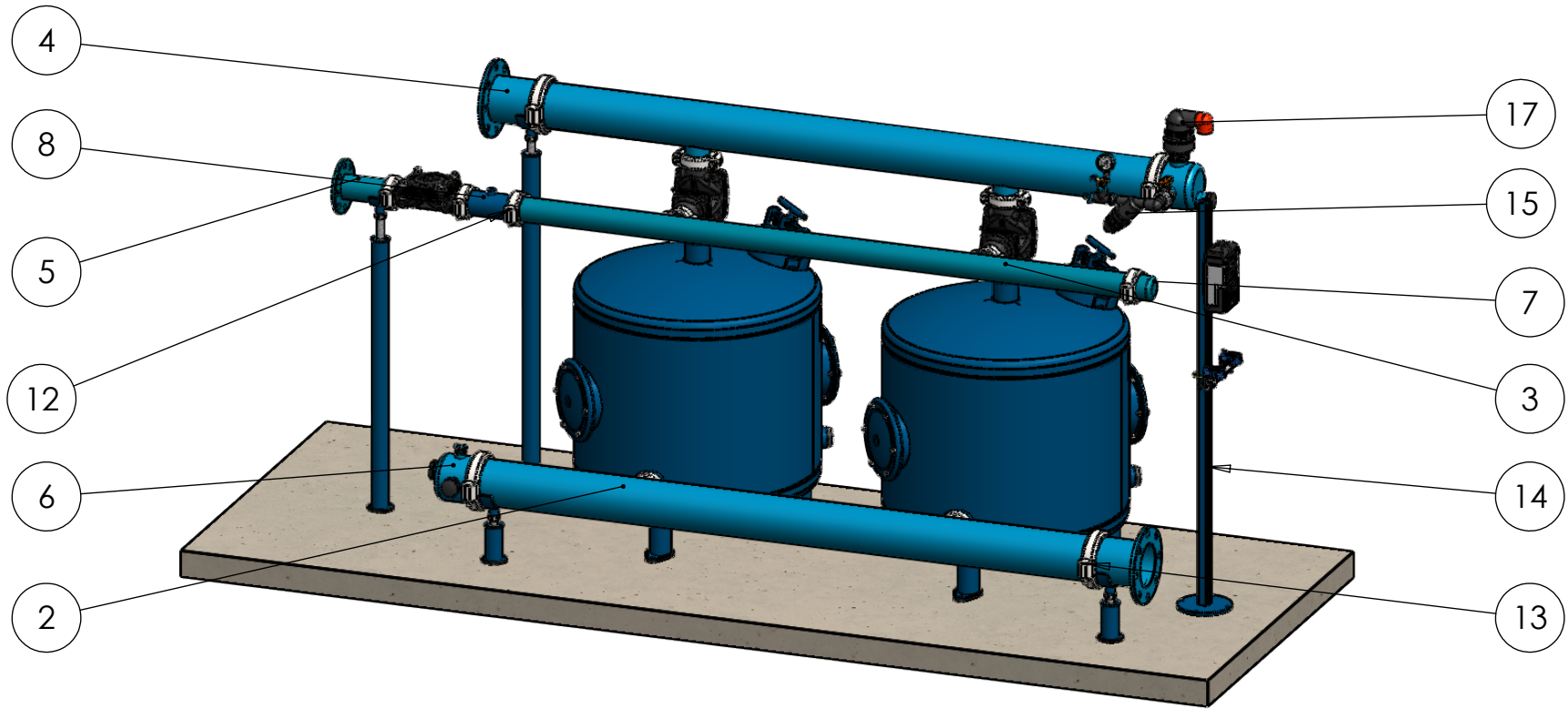

SAP DESCRIPTION: **Station Sandstorm 2 x 36"**

SKU No. **71910-003805**

Maximum Flow Rate: 100 m<sup>3</sup>/h

Recommended Flow Rate: 80 m<sup>3</sup>/h

Inlet Pressure: **8 Bar**

Sheet Size:  
A4

Scale:  
1:25

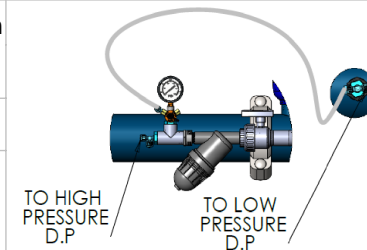

**PROPRIETARY AND CONFIDENTIAL**  
THE INFORMATION CONTAINED IN THIS DRAWING IS THE SOLE PROPERTY OF NETAFIM. ANY REPRODUCTION IN PART OR AS A WHOLE WITHOUT THE WRITTEN PERMISSION OF NETAFIM IS PROHIBITED

Designed By		
Drawn By	KEREM	21/11/2019
Checked By		
QA		
Sheet: 2	Of: 3	Rev. -

ITEM NO.	SAP Description	SAP Cat. No.	QTY.
1	METAL DBL.CHA.PLUS 36"*3" VIC PN08	71910-010045	2
2	METAL MAN 6"*2 OUT*3" VIC F/30-36" TANK	71910-001710	2
3	METAL BF MAN 3"*2 OUT*2" VIC F/30-36" T	71910-001709	1
4	METAL TRANSITION 6" ISO FLANGE*VIC	71910-002011	2
5	METAL TRANSITION 3" ISO FLANGE*VIC	71910-002005	1
6	MET CUP 6"VIC W/2 OUT 2"BSP+1 OUT 1"BSP	71910-001803	2
7	METAL CUP 3" VIC	71910-001791	1
8	METAL NIPPLE 3"*200MM VIC/VIC+(3/4" BSP)	71910-008980	1
9	NET METAL B.F VALVE 3X2 STRAIGHT VIC	71600-006670	2
10	S100CI 3" FCV+ORIFICE 20"-36"	71600-003417	1
11	VICTAULIC COUPLING 2" ONE BOLT	71910-002500	2
12	VICTAULIC COUPLING 3" ONE BOLT	71910-002501	10
13	VICTAULIC COUPLING 6" TWO BOLT	71910-002503	4
14	Control Stand	71910-000100	1
15	CONTROL KIT FOR MEDIA FILTER - BSP	37090-009600	1
16	AQUATIVE BRACKET DC 2 SOL-CONF.2	35500-000710	1
17	BARAK PLASTIC BASE 2" DG-010 (BSPT) NFR	70500-001180	1
18	SUPPORT LEG 6"-200MM	71910-001909	2
19	SUPPORT LEG 6"-1400MM	71910-001960	1
20	SUPPORT LEG 3"-1100MM	71910-001891	1
21	FLUSHING CONTR. DC 6 OUT.+DP SENS.	73240-003179	1
22	PE 8MM W/1 RED STRIPE - 100M	40000-013000	1
23	ACCESS KIT FOR METAL 20"/24" 4"+3" GASK.	37090-009730	1
24	POWER SUPPLY 100-240VAC/12VDC	73240-007240	1

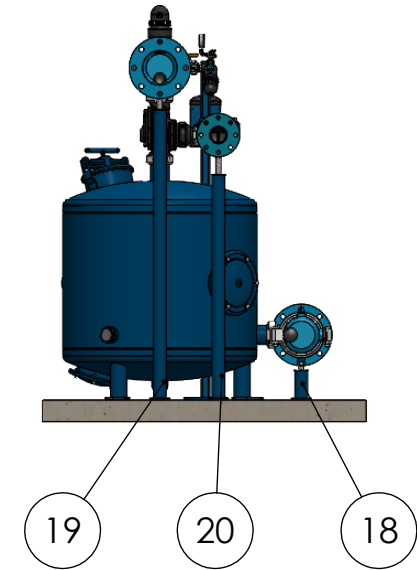
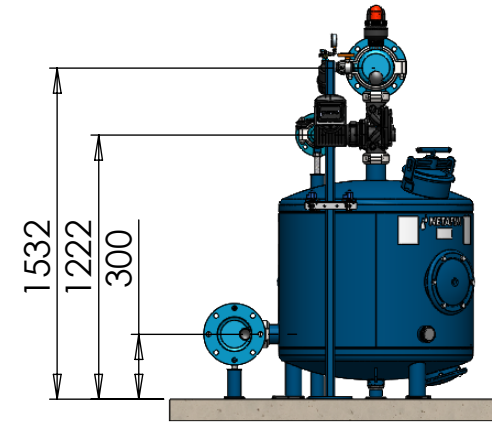

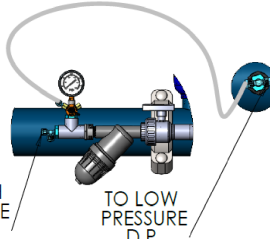
SAP DESCRIPTION: <b>Station Sandstorm 2 x 36"</b>		 <p><b>NETAFIM™</b></p> <p><b>PROPRIETARY AND CONFIDENTIAL</b> THE INFORMATION CONTAINED IN THIS DRAWING IS THE SOLE PROPERTY OF NETAFIM. ANY REPRODUCTION IN PART OR AS A WHOLE WITHOUT THE WRITTEN PERMISSION OF NETAFIM IS PROHIBITED</p>
SKU No.	<b>71910-003805</b>	
Maximum Flow Rate:	100 m <sup>3</sup> /h	
Recommended Flow Rate:	80 m <sup>3</sup> /h	
Inlet Pressure:	<b>8 Bar</b>	Designed By
Sheet Size:	A4	Scale:
		1:20
		Drawn By
		KEREM
		21/11/2019
		Checked By
		QA
		Sheet: 3
		Of: 3
		Rev. -