

SAP DESCRIPTION: **Station Sandstorm 3 x 36"**

SKU No. **71910-003905**

Maximum Flow Rate: 150m³/h
 Recommended Flow Rate: 120m³/h

Inlet Pressure: **8 Bar**

Sheet Size: **A4** Scale: **1:20**

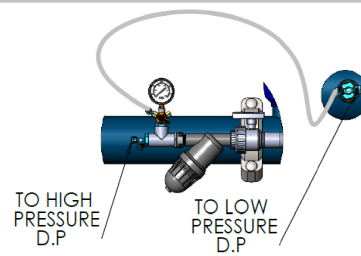

PROPRIETARY AND CONFIDENTIAL
 THE INFORMATION CONTAINED IN THIS DRAWING IS THE SOLE PROPERTY OF NETAFIM. ANY REPRODUCTION IN PART OR AS A WHOLE WITHOUT THE WRITTEN PERMISSION OF NETAFIM IS PROHIBITED

Designed By		
Drawn By	KEREM	21/11/2019
Checked By		
QA		
Sheet: 1	Of: 3	Rev. -

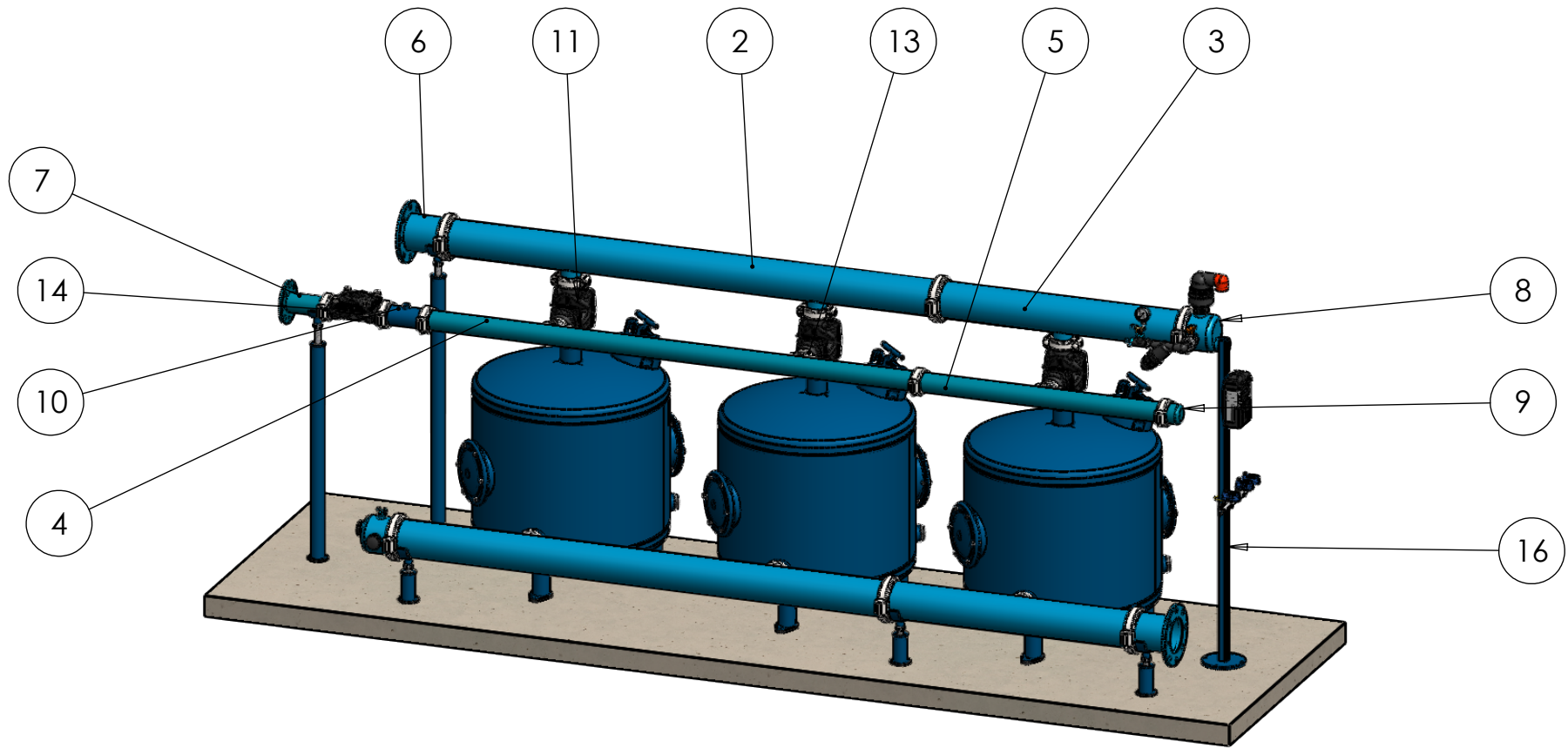

SAP DESCRIPTION: Station Sandstorm 3 x 36"	
SKU No.	71910-003905
Maximum Flow Rate:	150 m ³ /h
Recommended Flow Rate:	120 m ³ /h
Inlet Pressure:	8 Bar
Sheet Size:	Scale:
A4	1:30

NETAFIM™

PROPRIETARY AND CONFIDENTIAL
 THE INFORMATION CONTAINED IN THIS DRAWING IS THE SOLE PROPERTY OF NETAFIM. ANY REPRODUCTION IN PART OR AS A WHOLE WITHOUT THE WRITTEN PERMISSION OF NETAFIM IS PROHIBITED

Designed By		
Drawn By	KEREM	21/11/2019
Checked By		
QA		
Sheet: 2	Of: 3	Rev. -

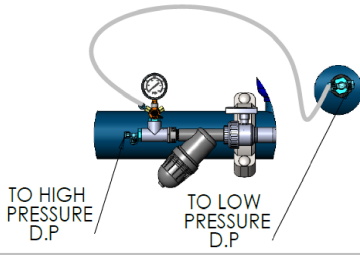

ITEM NO.	SAP Description	SAP Cat. No.	QTY.
1	METAL DBL.CHA.PLUS 36"*3" VIC PN08	71910-010045	3
2	METAL MAN 6"*2 OUT*3" VIC F/30-36" TANK	71910-001710	2
3	METAL MAN 6"*1 OUT*3" VIC F/30-36" TANK	71910-001701	2
4	METAL BF MAN 3"*2 OUT*2" VIC F/30-36" T	71910-001709	1
5	METAL BF MAN 3"*1 OUT*2" VIC F/30-36" T	71910-001700	1
6	METAL TRANSITION 6" ISO FLANGE*VIC	71910-002011	2
7	METAL TRANSITION 3" ISO FLANGE*VIC	71910-002005	1
8	MET CUP 6"VIC W/2 OUT 2"BSP+1 OUT 1"BSP	71910-001803	2
9	METAL CUP 3" VIC	71910-001791	1
10	METAL NIPPLE 3"*200MM VIC/VIC+(3/4" BSP)	71910-008980	1
11	NET METAL B.F VALVE 3X2 STRAIGHT VIC	71600-006670	3
12	S100CI 3" FCV+ORIFICE 20"-36"	71600-003417	1
13	VICTAULIC COUPLING 2" ONE BOLT	71910-002500	3
14	VICTAULIC COUPLING 3" ONE BOLT	71910-002501	14
15	VICTAULIC COUPLING 6" TWO BOLT	71910-002503	6
16	Control Stand	71910-000100	1
17	CONTROL KIT FOR MEDIA FILTER - BSP	37090-009600	1
18	AQUATIVE BRACKET DC 3 SOL-CONF.2	35500-000711	1
19	BARAK PLASTIC BASE 2" DG-010 (BSPT) NFR	70500-001180	1
20	SUPPORT LEG 6"-200MM	71910-001909	3
21	SUPPORT LEG 6"-1400MM	71910-001960	1
22	SUPPORT LEG 3"-1100MM	71910-001891	1
23	FLUSHING CONTR. DC 6 OUT.+DP SENS.	73240-003179	1
24	PE 8MM W/1 RED STRIPE - 100M	40000-013000	1
25	ACCESS KIT FOR METAL 20"/24" 4"+3" GASK.	37090-009730	1
26	POWER SUPPLY 100-240VAC/12VDC	73240-007240	1

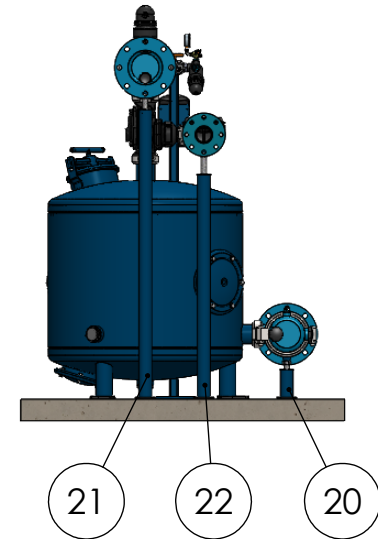
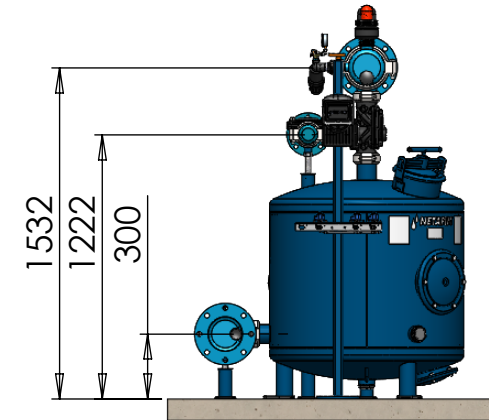

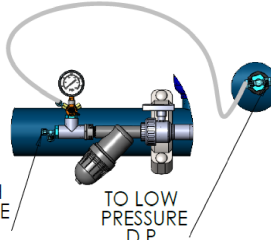
SAP DESCRIPTION: Station Sandstorm 3 x 36"		 <p>NETAFIM™</p> <p><small>PROPRIETARY AND CONFIDENTIAL THE INFORMATION CONTAINED IN THIS DRAWING IS THE SOLE PROPERTY OF NETAFIM. ANY REPRODUCTION IN PART OR AS A WHOLE WITHOUT THE WRITTEN PERMISSION OF NETAFIM IS PROHIBITED</small></p>
SKU No.	71910-003905	
Maximum Flow Rate:	150m ³ /h	
Recommended Flow Rate:	120m ³ /h	
Inlet Pressure:	8 Bar	Designed By
Sheet Size:	A4	Scale:
	1:20	Drawn By
		Checked By
		QA
		Sheet: 3 Of: 3 Rev. -